

<b>Gas Appliances Directive ( 90/396/EEC )</b>	
<b>GUIDANCE A 1</b>	<b>Approved by WG -GA 06 - 2003</b>

**Guideline related to:**

<b>CHAPTER</b>	<b>I</b>	<b>Scope, placing on the market and free movement</b>
<b>Article</b>	<b>1</b>	
<b>Paragraph</b>	<b>1</b>	
<b>Subject</b>	<b>Appliances and fittings covered by the Directive</b>	

Article 1
<p>1. This Directive shall apply to:</p> <ul style="list-style-type: none"> <li>— appliances burning gaseous fuels used for cooking, heating, hot water production, refrigeration, lighting or washing and having, where applicable, a normal water temperature not exceeding 105 °C, hereinafter referred to as 'appliances'. Forced draught burners and heating bodies to be equipped with such burners will also be considered as appliances,</li> <li>— safety devices, controlling devices or regulating devices and subassemblies, other than forced draught burners and heating bodies to be equipped with such burners separately marketed for trade use and designed to be incorporated into an appliance burning gaseous fuel or assembled to constitute such an appliance, hereinafter referred to as 'fittings'.</li> </ul>

**Question**

Which appliances and components are considered as covered by the Gas Appliances Directive?

**Discussion**

The GAD gives product categories, which are within the scope, but does not contain list of specific products covered.

However, in order to facilitate judgement whether an individual product is covered by the Directive, an illustrative list has been drawn up by all parties concerned.

A note to the list explains the meaning of some wording used.

Furthermore, some specific elements of certain product categories are clarified on separate Guidance Sheets.

**Note**

Attention is drawn to the fact that the term fitting as used by industry is generally broader than the term fitting as defined in the Directive.

**Conclusion**

See the following illustrative list which is non-exhaustive and will be amended as necessary. As example and for clarification, a list of certain exceptions is also shown in each section.

./..

*This guidance is for information only; it has no formal status*

*Reference: 90/396/EEC "Gas appliances directive" O.J. L 196, 26.07.90, p. 15*

*Source of guidance document: GADAC*

<b>Doc. Number</b>	<b>Rev. Number</b>	<b>Approved by GADAC</b>	<b>Approved by WG-GA</b>	<b>Withdrawn</b>
<b>A1</b>	<b>0</b>	<b>06/2003</b>	<b>06/2003</b>	<b>--</b>

## Note

1. *The Gas Appliances Directive covers appliances used for:*
  - cooking
  - heating
  - hot water production
  - refrigeration
  - lighting
  - washing (including ironing)
2. *The Directive does not apply to appliances when normal water temperature exceeds 105 °C. However, where water temperature exceeds 105 °C for a short period, e.g. café boilers and coffee machines, the appliances remain within the scope.*
3. *In the context of the Directive, each single marketed unit burning gaseous fuel(s) is considered to be an appliance that must meet the requirements of the Directive.*
4. *The Directive specifically identifies forced draught burners and heating bodies to be equipped with such burners as appliances.*
5. *The Directive also covers safety devices, controlling devices or regulating devices and sub-assemblies separately marketed for trade use and designed to be incorporated into an appliance burning gaseous fuel or assembled to constitute such an appliance. These are defined as fittings.*
6. *The items referred to in point 5, having no impact to the safe functionality of the appliance, are not considered to be covered.*
7. *The items referred to in point 5, if incorporated into an appliance or assembled to constitute such an appliance before their placing on the market and/or putting into service, are considered as part of the appliance.*
8. *The items referred to in point 5, which are specifically for an appliance manufacturer's own use, even where this manufacture is sub-contracted, and therefore are not separately marketed for trade use, are not within the scope.*
9. *Appliances specifically designed for use in industrial processes carried out on industrial premises are excluded (see: document number A5).*
10. *Components such as, flue dampers, fanned flue systems and flue systems placed on the market with an appliance are considered as part of the appliance (see: document number A3).*

./..

---

*This guidance is for information only; it has no formal status*

*Reference: 90/396/EEC "Gas appliances directive" O.J. L 196, 26.07.90, p. 15*

*Source of guidance document: GADAC*

<b>Doc. Number</b>	<b>Rev. Number</b>	<b>Approved by GADAC</b>	<b>Approved by WG-GA</b>	<b>Withdrawn</b>
<b>A1</b>	<b>0</b>	<b>06/2003</b>	<b>06/2003</b>	<b>--</b>

## APPLIANCES

### **A. Cooking**

- hotplate
- cooker
- barbecue/grill
- baking oven (also in-shop type)
- oven (also in-shop type)
- range
- steamer
- bain marie
- hot cupboard
- boiling table
- grill
- griddle
- toaster
- fryer
- brat pan
- coffee machine (even if the water temperature in a short period exceeds 105° C)
- wok cooker
- humidifiers (based on the way of heat is generated, the appliance is also used for heating)

### **Exceptions :**

- factory baking oven

### **B. Heating**

- forced draught burner (FDB)
- heating body (to be equipped with FDB)
- gas fire
- convector heater
- decorative fuel effect appliance
- catalytic heater
- air heater with or without ducting
- overhead plaque type radiant heater
- overhead radiant tube heater
- patio heater
- boiler (inc. district heating)
- heat pump (absorption and compression)
- green house heater
- humidifiers (see under cooking)
- co-generation appliances (where the primary function is heating)
- fuel cells (where the primary function is heating)

### **Exceptions**

- blow lamp
- cutting/brazing equipment
- laboratory burner
- incinerator
- greenhouse heater for industrial use

*This guidance is for information only; it has no formal status*

*Reference: 90/396/EEC "Gas appliances directive" O.J. L 196, 26.07.90, p. 15*

*Source of guidance document: GADAC*

Doc. Number	Rev. Number	Approved by GADAC	Approved by WG-GA	Withdrawn
A1	0	06/2003	06/2003	--

**C. Hot water production**

- instantaneous water heaters
- storage water heaters
- circulator
- combination boiler
- swimming pool heater
- boiling pan
- bulk water boiler
- cafe boiler (even if the water temperature in a short period exceeds 105 °C)

**Exceptions :**

- appliances with normal water temperature > 105 °C

**D. Refrigeration**

- refrigerator
- chiller
- deep-freezer
- air conditioning

**E. Washing**

- wash boiler
- washing machine
- drying cabinet
- tumble dryer
- dish washing machine
- ironing machine

**Exceptions :**

- industrial laundry

**F. Lighting**

- gas lamp
- lighting appliances

**FITTINGS**

- appliance governor
- multifunctional control
- solenoid valve
- flame supervision device
- burner control system
- ball valve
- gas cock
- low pressure cut-off valve
- gas tap
- thermostat
- safety overheat thermostat
- flue thermostat
- pressure sensing device
- filter
- igniters

---0---

*This guidance is for information only; it has no formal status*

*Reference: 90/396/EEC "Gas appliances directive" O.J. L 196, 26.07.90, p. 15*

*Source of guidance document: GADAC*

Doc. Number	Rev. Number	Approved by GADAC	Approved by WG-GA	Withdrawn
A1	0	06/2003	06/2003	--

<b>Gas Appliances Directive ( 90/396/EEC )</b>	
<b>GUIDANCE A 2</b>	<b>Approved by WG -GA 06 - 2003</b>

**Guideline related to:**

<b>CHAPTER</b>	<b>I</b>	<b>Scope, placing on the market and free movement</b>
<b>Article</b>	<b>1</b>	
<b>Paragraph</b>	<b>1</b>	
<b>Subject</b>	<b>Interpretation of “heating”</b>	

Article 1
<p>1. This Directive shall apply to:</p> <ul style="list-style-type: none"> <li>— appliances burning gaseous fuels used for cooking, heating, hot water production, refrigeration, lighting or washing and having, where applicable, a normal water temperature not exceeding 105 °C, hereinafter referred to as ‘appliances’. Forced draught burners and heating bodies to be equipped with such burners will also be considered as appliances,</li> <li>— safety devices, controlling devices or regulating devices and subassemblies, other than forced draught burners and heating bodies to be equipped with such burners separately marketed for trade use and designed to be incorporated into an appliance burning gaseous fuel or assembled to constitute such an appliance, hereinafter referred to as ‘fittings’.</li> </ul>

**Question**

Some linguistic versions of the directive suggest that heating covers only space heating, whilst others allow a wider interpretation. The question therefore arises, whether “heating” covers only space heating or also other applications of heating?

**Discussion**

Article 1.1 gives specific list of the types of applications covered.

It results from this list that when the application/use implies the heating of some material (e.g. food, water etc.), this is already separately indicated.

Therefore, heating refers in this context to space heating and not to the application of heat for other purposes.

**Conclusion**

Heating refers only to space heating.

---O---

*This guidance is for information only; it has no formal status*  
Reference: 90/396/EEC “Gas appliances directive” O.J. L 196, 26.07.90, p. 15  
Source of guidance document: GADAC

Doc. Number	Rev. Number	Approved by GADAC	Approved by WG-GA	Withdrawn
<b>A2</b>	<b>0</b>	<b>06/2003</b>	<b>06/2003</b>	<b>--</b>

<b>Gas Appliances Directive ( 90/396/EEC )</b>	
<b>GUIDANCE A 3</b>	<b>Approved by WG -GA</b>
	-

**Guideline related to:**

<b>CHAPTER</b>	<b>I</b>	<b>Scope, placing on the market and free movement</b>
<b>Article</b>	<b>1</b>	
<b>Paragraph</b>	<b>1</b>	
<b>Subject</b>	<b>Connecting hoses and regulators used to connect appliances to the fuel source; Other components affecting gas safety</b>	

Article 1
<p>1. This Directive shall apply to:</p> <ul style="list-style-type: none"> <li>— appliances burning gaseous fuels used for cooking, heating, hot water production, refrigeration, lighting or washing and having, where applicable, a normal water temperature not exceeding 105 °C, hereinafter referred to as 'appliances'. Forced draught burners and heating bodies to be equipped with such burners will also be considered as appliances,</li> <li>— safety devices, controlling devices or regulating devices and subassemblies, other than forced draught burners and heating bodies to be equipped with such burners separately marketed for trade use and designed to be incorporated into an appliance burning gaseous fuel or assembled to constitute such an appliance, hereinafter referred to as 'fittings'.</li> </ul>

**Question**

- Are connecting hoses and regulators used for connecting an appliance to the fuel source covered by the Directive?
- Are other components affecting gas safety covered by the Directive?

**Discussion**

1. Where the connecting hose and a regulator used to connect appliances to the fuel source, are placed on the market together as a complete appliance, they are considered as being part of the appliance which is within the scope of the Directive.
2. Where a connecting hose is supplied separately, it is not considered to be a fitting and therefore it is not within the scope of the Directive.
3. When a regulator is supplied separately, it would not normally be considered as a fitting in its own right, unless it is specifically intended for an appliance as described in point 1.

*This guidance is for information only; it has no formal status*

Reference: 90/396/EEC "Gas appliances directive" O.J. L 196, 26.07.90, p. 15

Source of guidance document: GADAC

<b>Doc. Number</b>	<b>Rev. Number</b>	<b>Approved by GADAC</b>	<b>Approved by WG-GA</b>	<b>Withdrawn</b>
<b>A3</b>	<b>1</b>	<b>10/2009</b>	<b>11/2009</b>	<b>--</b>

4. Where the appliance is placed on the market without a connecting hose or a regulator, the instructions for use accompanying the appliance must cover the safe connection to the fuel source.
5. A similar argument applies for other components affecting gas safety such as flue dampers, fanned flue systems and flue systems.

./..

## Conclusion

Connecting hoses and regulators are covered by the Directive, in as far as they are placed on the market as (part of) a complete appliance and the complete appliance is identified with a unique appliance identifier.

Other components affecting gas safety such as, amongst others, flue dampers, flue systems and fanned flue systems, are covered by the Directive, in as far as they are placed on the market as (part of) a complete appliance and the complete appliance is identified with a unique appliance identifier.

## Note:

It has to be considered that the fuel supply network in each Member State is subject to national legislation. Therefore there are many different sizes and shaped connectors for connecting to the connector of the fuel supply outlet.

The use of the right connectors is very important for the safety of gas appliances, as inappropriate connectors may give rise to dangerous situations due to gas leaks. It results that the connectors have to be compatible with the characteristics of the gas supply network in each country.

---0---

*This guidance is for information only; it has no formal status*

Reference: 90/396/EEC "Gas appliances directive" O.J. L 196, 26.07.90, p. 15

Source of guidance document: GADAC

Doc. Number	Rev. Number	Approved by GADAC	Approved by WG-GA	Withdrawn
A3	1	10/2009		--

<b>Gas Appliances Directive ( 90/396/EEC )</b>	
<b>GUIDANCE A 4</b>	<b>Approved by WG -GA 06 - 2003</b>

**Guideline related to:**

<b>CHAPTER</b>	<b>I</b>	<b>Scope, placing on the market and free movement</b>
<b>Article</b>	<b>1</b>	
<b>Paragraph</b>	<b>1</b>	
<b>Subject</b>	<b>Forced draught burners and heating bodies</b>	

Article 1	
<p>1. This Directive shall apply to:</p> <ul style="list-style-type: none"> <li>— appliances burning gaseous fuels used for cooking, heating, hot water production, refrigeration, lighting or washing and having, where applicable, a normal water temperature not exceeding 105 °C, hereinafter referred to as 'appliances'. Forced draught burners and heating bodies to be equipped with such burners will also be considered as appliances,</li> <li>— safety devices, controlling devices or regulating devices and subassemblies, other than forced draught burners and heating bodies to be equipped with such burners separately marketed for trade use and designed to be incorporated into an appliance burning gaseous fuel or assembled to constitute such an appliance, hereinafter referred to as 'fittings'.</li> </ul>	

**Question**

Are forced draught burners and heating bodies to be equipped with such burners to be considered as appliances?

**Discussion**

The origin of this question is the different linguistic versions of the Directive. Certain language versions refer to the heating bodies already equipped with forced draught burners. This raises questions as regard whether heating bodies to be equipped with these forced draught burners can be considered as gas appliances.

The history of the adoption process of the Directive suggests that it was the intention of the legislator to cover such bodies as appliances.

**Conclusion**

The Directive should be interpreted that both forced draught burners and heating bodies to be equipped with such burners, are considered as appliances.

---0---

*This guidance is for information only; it has no formal status*

Reference: 90/396/EEC "Gas appliances directive" O.J. L 196, 26.07.90, p. 15

Source of guidance document: GADAC

Doc. Number	Rev. Number	Approved by GADAC	Approved by WG-GA	Withdrawn
<b>A4</b>	<b>0</b>	<b>06/2003</b>	<b>06/2003</b>	<b>--</b>



<b>Gas Appliances Directive ( 90/396/EEC )</b>	
<b>GUIDANCE A 5</b>	<b>Approved by WG -GA 06 - 2003</b>

**Guideline related to:**

<b>CHAPTER</b>	<b>I</b>	<b>Scope, placing on the market and free movement</b>
<b>Article</b>	<b>1</b>	
<b>Paragraph</b>	<b>2</b>	
<b>Subject</b>	<b>Industrial processes carried out on industrial premises</b>	

Article 1
..... 2. Appliances specifically designed for use in industrial processes carried out on industrial premises are excluded from the scope defined in paragraph 1.

**Question**

How should the exclusion defined in Article 1.2 be interpreted?

**Discussion**

This provision, being an exclusion from the Directive, should be interpreted in a strict way.

In order to manage the risks related to gas appliances, the exclusion is justified in as far as safety aspects would be taken into consideration as part of the industrial process in industrial premises and in the specific design.

In this context:

“*Industrial process*” should be understood as the extraction, growth, refining, processing, production, manufacture or preparation of materials, plants, livestock, animal products, food or other products with a view to its commercial use.

“*Specific design*” should be understood as a design for an appliance when that design is only intended to address a specific need for a specified process.

“*Industrial premises*” should be understood as any place where the main activity carried out is an industrial process that normally would be subject to specific national health and safety regulations. Normally, activities associated with retail sale or wholesale trade, would not be covered by this exclusion.

The following examples could clarify the situation:

1. *Industrial process / non-industrial premises: Directive applies.*  
An example of this situation is a supermarket where the main activity is retail sale of groceries to the public but which has an in-store bakery making products for sale on the premises.

./..

*This guidance is for information only; it has no formal status*

Reference: 90/396/EEC “Gas appliances directive” O.J. L 196, 26.07.90, p. 15

Source of guidance document: GADAC

Doc. Number	Rev. Number	Approved by GADAC	Approved by WG-GA	Withdrawn
<b>A5</b>	<b>0</b>	<b>06/2003</b>	<b>06/2003</b>	--

2. Non-industrial process / industrial premises: Directive applies.  
An example of this situation is the provision of space heating and catering services for employees working in a factory.
3. Non-industrial process / non-industrial premises: Directive applies.  
This includes domestic and commercial situations.

### **Conclusions**

It needs to be considered on a case by case basis whether the appliance is both specifically designed for use in industrial process and intended to be put into service on industrial premises. Only if all these requirements are fulfilled, is the appliance excluded from the scope of the Directive.

---0---

*This guidance is for information only; it has no formal status*

Reference: 90/396/EEC "Gas appliances directive" O.J. L 196, 26.07.90, p. 15

Source of guidance document: GADAC

Doc. Number	Rev. Number	Approved by GADAC	Approved by WG-GA	Withdrawn
<b>A5</b>	<b>0</b>	<b>06/2003</b>	<b>06/2003</b>	--

<b>Gas Appliances Directive ( 90/396/EEC )</b>	
<b>GUIDANCE B 1</b>	<b>Approved by WG -GA 06 - 2003</b>

**Guideline related to:**

<b>ANNEX</b>	<b>I</b>	<b>Essential requirements</b>
<b>Section</b>	<b>1</b>	<b>General conditions</b>
<b>Paragraph</b>	<b>1.1.</b>	
<b>Subject</b>	<b>Hazard related to accessible flames (Fire guarding)</b>	

1. GENERAL CONDITIONS

1.1. Appliances must be so designed and built as to operate safely and present no danger to persons, domestic animals or property when normally used as defined in Article 1 (4) of this Directive.

**Question**

For heating appliances with accessible flames or incandescent parts there is a potential fire and injury risk where clothing or drapery might accidentally brush against them.

How do the essential requirements address this hazard?

**Discussion**

It should be reasonably foreseen that persons come close to the appliance with accessible flames. These appliances represent an increasingly important market, including also mobile appliances.

Essential Requirement 1.1. states that “appliances must be so designed and built as to operate safely and present no danger to persons, domestic animals or property when normally used” and Essential Requirement 1.2. states that appliances must be accompanied by instructions for the installer, for the user and appropriate warning notices.

- In order to deal in a appropriate way with the risk of access to flames and ensure safety of these appliances, under normal conditions of use, the manufacturer must in the first place deal with this risk by design (e.g. to fit a fireguard, known in some countries as a dress guard). The risk may also be appropriately dealt with by design and instructions for the installer to install the appliance in such a way that it would be safe by position.
- Though it is important that users both read and follow the user instruction provided with an appliance, it is unlikely that user instructions would effectively address the particular hazard addressed here. The hazard being of accidental contact with very hot surfaces or flames by people in the vicinity of the heating appliance. People who can be expected to have never read the user

*This guidance is for information only; it has no formal status*

Reference: 90/396/EEC “Gas appliances directive” O.J. L 196, 26.07.90, p. 15

Source of guidance document: GADAC

<b>Doc. Number</b>	<b>Rev. Number</b>	<b>Approved by GADAC</b>	<b>Approved by WG-GA</b>	<b>Withdrawn</b>
<b>B1</b>	<b>0</b>	<b>06/2003</b>	<b>06/2003</b>	<b>--</b>

instructions (e.g. visitors) or who will be carrying out activities where the appliance will be seen as a hazard free piece of furnishing and will not be perceived as a risk.

It would be expected that where appropriate the user instructions would provide guidance to the user (as owner of the appliance) as to how to provide any additional recommended protection for at risk users as described in various ISO Guides e.g. young children, the older person and persons with disabilities. Such recommendations may include the provision of additional fire guarding by the user.

### **Conclusion**

The hazard identified must be addressed by design (Essential Requirement 1.1.) or by a combination of design and instructions for the installer (Essential Requirements 1.1. and 1.2.).

---0---

*This guidance is for information only; it has no formal status*

Reference: 90/396/EEC "Gas appliances directive" O.J. L 196, 26.07.90, p. 15

Source of guidance document: GADAC

<b>Doc. Number</b>	<b>Rev. Number</b>	<b>Approved by GADAC</b>	<b>Approved by WG-GA</b>	<b>Withdrawn</b>
<b>B1</b>	<b>0</b>	<b>06/2003</b>	<b>06/2003</b>	<b>--</b>

<b>Gas Appliances Directive ( 90/936/EEC)</b>	
<b>GUIDANCE B2</b>	<b>Approved by WG-GA</b> <b>03-2009</b>

**Guidance related to:**

<b>ANNEX</b>	<b>I</b>	<b>Essential requirements</b>
<b>Section</b>	<b>1</b>	<b>General conditions</b>
<b>Paragraph</b>	<b>1.1</b>	
<b>Subject</b>	<b>Safety in relation to electromagnetic phenomena</b>	

**1. GENERAL CONDITIONS**

Appliances must be so designed and built as to operate safely and present no danger to persons, domestic animals or property when normally used as defined in Article 1 (4) of this Directive

**Question**

For gas appliances incorporating electrical and/or electronic components, how are gas safety risks related to electromagnetic phenomena dealt with by the Directive?

**Discussion**

1. Gas appliances incorporating electrical and/or electronic components can be sensitive to electromagnetic phenomena. This may affect either the proper functioning of the appliance or the safety of the appliance.
2. Two related issues may be considered as being associated with gas appliances:
  - 2.1. The proper functioning of the appliance in its environment and the disturbances caused by the appliance (EMC immunity and emissions).
  - 2.2. The safety of the appliance towards persons, domestic animals and property.

The aspect in 2.1 is considered under the Directives 89/336/EEC and/or 2004/108/EC on electromagnetic compatibility (EMC Directive)

The aspect in 2.2 must also be considered under the GAD.
3. From the GAD point of view, the essential requirements do not specifically address the gas safety risks due to electromagnetic phenomena. This aspect has to be considered as part of the general essential requirement 1.1 which states *“appliances must be so designed and built as to operate safely and present no danger to persons, domestic animals and property when normally used”*.
4. When issuing an EC Type Examination certificate for gas appliances containing electrical and/or electronic components, the Notified Body must consider the influence of electromagnetic phenomena on the gas safety of the appliance and ensure that the safety of the appliance is not degraded when used normally and subjected to such phenomena.

Doc. number	Rev. number	Approved by GADAC	Approved by WG-GA	Withdrawn
B2	1	10/2008	03-2009	

## **Conclusion**

1. Both the GAD and the EMC Directive apply to gas appliances incorporating electrical and/or electronic components. The issues associated with the proper functioning of the appliance are considered under the EMC Directive, whilst the risks associated with the safety of the appliance are considered under the GAD.
2. GAD essential requirement 1.1 implies that when used normally and subjected to electromagnetic phenomena, gas appliances shall operate safely.
3. The applicable requirements of EN 60335-2-102 clause 19.11.4 or EN 50165 clause 19.101 (until DOW 1 April 2009) can be considered as an adequate means to address the risks associated with electromagnetic phenomena for gas appliances with safety-related electrical or electronic systems.
4. The Notified Body has to verify that the applicable requirements are met.
5. Appropriate test documentation provided by the manufacturer may be used to avoid the duplication of testing.

-----

Doc. number	Rev. number	Approved by GADAC	Approved by WG-GA	Withdrawn
B2	1	10/2008	03-2009	

**PAGES** 1-5

**ANNEX** I **Essential requirements**

**SECTION** 1 **General conditions**

**PARAGRAPH** 1.2.1

**SUBJECT** **Boiler body / forced draught burner matching**

*“The technical instructions intended for the installer must contain all the instructions for installation, adjustment and servicing required ensuring that those operations are correctly performed and that the appliance may be used safely. In particular, the instructions must specify:*

...

- *for forced draught burners and boiler bodies intended to be equipped with such burners, their characteristics, the requirements for assembly, to assist compliance with the essential requirements applicable to finished appliances and, where appropriate, the list of combinations recommended by the manufacturer.”*

### **Question**

Boiler bodies are covered by the definition of heating bodies mentioned in the Directive. How should the manufacturer(s) of the forced draught burner and boiler body provide the information referred to in the last indent of Essential Requirement 1.2.1 to ensure safe boiler body/burner matching?

### **Discussion**

Forced draught burners and the boiler bodies to be equipped with such burners when placed on the market separately need to be matched safely.

Normally, a forced draught burner is fitted to the boiler body at the place of putting into service by the installer.

In order to make sure that the combination will be in conformity with the Essential Requirements, manufacturers of the forced draught burners and boiler bodies must specify adequate information to ensure the burner/boiler matching can be carried out safely.

**The manufacturer of forced draught burners**, who markets the burners separately, must:

- assure that the burners are tested and certified on the basis of use of a test rig which simulates the boiler bodies, and
- either indicate in the instructions for installation the necessary technical information for matching the burners to the boiler bodies,
- or on the basis of the technical information, where appropriate, draw up a list of recommended combinations.

This matter is covered by harmonised standard EN 676.

---



---

*This guidance is for information only; it has no formal status*

Reference: 90/396/EEC “Gas appliances directive” O.J. L 196, 26.07.90, p. 15

Source of guidance document: GADAC

1

Doc. Number	Rev. Number	Approved by GADAC	Approved by WG-GA	Withdrawn
B3	1.1	10/2004	02/2005	

**The manufacturer of boiler bodies** has two options:

**First option** (restricted use of burners)

- To identify the specific forced draught burners which may be used with the boiler body; and
- To list the identified burners in the instructions.

**Second option** (separate market for boiler bodies)

- To specify in the instructions the interface requirements for the forced draught burner.

**Conclusion**

Manufacturers of forced draught burners and boiler bodies shall provide sufficient instructions either specifying the boiler body and burner combinations, or provide sufficient interface information to allow pairs to be matched safely.

The Annex gives detailed information on a procedure for ensuring safe boiler body / forced draught burner matching.

Doc. Number	Rev. Number	Approved by GADAC	Approved by WG-GA	Withdrawn
B3	1.1	10/2004	02/2005	



**ANNEX**1 General

- The burner shall be suitable for combination with boiler bodies, which can be assured by fulfilling the requirements of harmonised standard EN 676.
- The boiler body shall be suitable for combination with a burner, which can be assured by fulfilling the requirements of EN 303-1.
- The combination of boiler body and forced draught burner shall fulfil the essential requirements of the GAD, which can be assured by testing at least one assembly (a boiler body with a forced draught burner) according EN 303-3.

2 Options2.1 List

The manufacturers establish a list of recommended combinations in accordance with Essential Requirement 1.2.1 (last indent). This list shall be based either on tests or on criteria set out in the Guidance Sheet and this Annex to it.

The installer may select the appropriate combination of boiler body and burner by reference to the list.

2.2 Technical instructions

The technical instructions shall include the necessary information to permit the installer, responsible for the installation, and the commissioning of the finished appliance, to verify that when installed it does meet the Essential Requirements.

3 Procedure

The procedure mentioned hereafter will be part of the manufacturer's instruction for the installer.

3.1 Criteria for matching a boiler body/burner

The criteria mentioned hereafter do not apply to assemblies designed as units and tested as such. Such an assembly will be marketed as a complete boiler (unit).

- 3.1.1 The minimum dimensions of the combustion chamber shall not be smaller than the values specified in diagram 1.

Doc. Number	Rev. Number	Approved by GADAC	Approved by WG-GA	Withdrawn
B3	1.1	10/2004	02/2005	

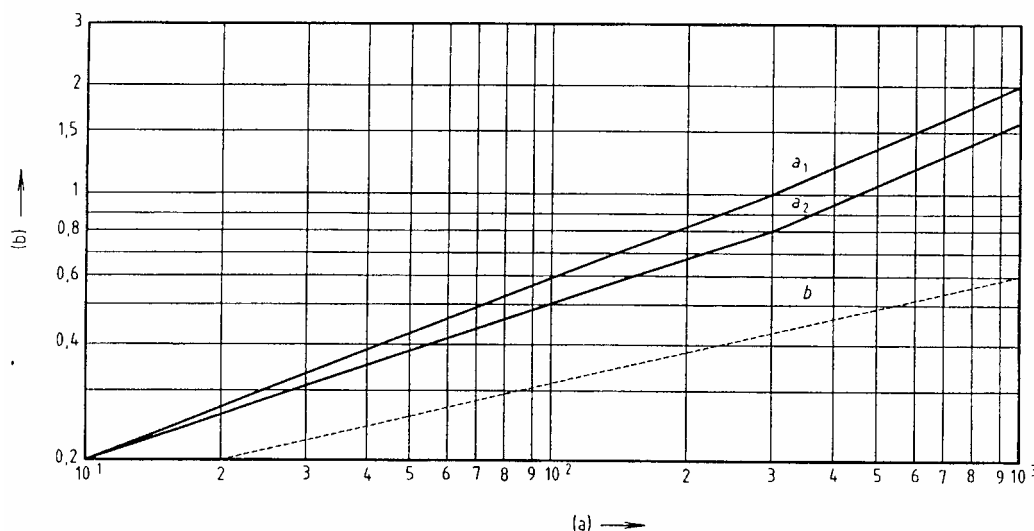

**Diagram 1: Minimum dimensions of the combustion chamber**

whereby (see EN 303-3:1998):

(a) = Nominal useful output  $P_n$  in kW

(b) = Diameter and length of the combustion chamber in m

the dimension "a" is the distance from the deflector plate of the burner up to the opposite wall of the combustion chamber.

- $a_1$  = Minimum length for combustion chamber with direct flame
- $a_2$  = Minimum length for combustion chamber with flame reversal

For a combustion chamber designed for reverse flame and with a heat input greater than 300 kW, the length "a" can be reduced by 20%.

For boilers with a heat input between 10 kW and 300 kW the reduction of "a" occurs proportionally to the heat input between 0% and 20%.

the dimension "b" is the diameter of the circular combustion chamber or the minimum sectional dimension in the case of a non circular combustion chamber.

- 3.1.2 The resistance of the combustion chamber corresponding to the nominal heat input shall be in accordance with the working diagram of the burner, as defined in EN 676.
- 3.1.3 The operation mode of the burner (on/off, two stage or modulation) shall be in accordance with the instructions given by the boiler body manufacturer.
- 3.1.4 The minimum heat input of the burner shall not be set to a lower value than the minimum heat input, declared by the boiler body manufacturer.

Doc. Number	Rev. Number	Approved by GADAC	Approved by WG-GA	Withdrawn
B3	1.1	10/2004	02/2005	

### 3.2 Technical documentation

3.2.1 The boiler body manufacturer shall specify in accordance with EN 303-1 and EN 303-3 the following data:

- nominal heat input;
- the operation mode for which the boiler body has been designed (on-off, multistage, modulating). The minimum heat input, below which value the burner may not operate in case of boiler bodies intended to be fired by a multistage or modulating burner;
- the flow resistance of the combustion chamber ( $\lambda = 1,2$ ) at nominal heat input;
- the type of combustion chamber (direct evacuation or reversed combustion);
- the length "a" of the combustion chamber, see figure 1;
- the diameter or, in case of a non circular combustion chamber, the minimum sectional dimension;
- the burner penetration "x" and the geometry of the assembly flange, see figure 1;
- relevant warnings (operation).
- temperature of combustion products,  $\text{CO}_2$  (or  $\text{O}_2$ ) and CO values.

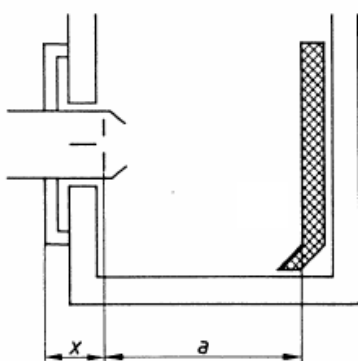

$a$ : length of combustion chamber with or without fire brick  
 $x$ : distance between burner flange and nozzle, given by the manufacturer

**Figure 1 Burner - boiler assembly**

3.2.2 The burner manufacturer shall specify in accordance with EN 676 the following data:

- maximum and minimum heat input;
- the working diagram;
- the dimensions of the burner head;
- the burner penetration ( $x$ ) and the geometry of the assembly flange, see figure 1;
- the connection dimensions;
- relevant warnings (operation).

### 3.3 Test report

The installer shall draw up a test report containing checks and adjustments related to the boiler body and the burner specifications and the adjustments carried out.

Doc. Number	Rev. Number	Approved by GADAC	Approved by WG-GA	Withdrawn
B3	1.1	10/2004	02/2005	

## 3.3.1 The installer shall indicate:

- the address and name where the assembly is installed;
- the name and type of the certified boiler body to EN 303-1/303-3;
- the name and type of the certified burner to EN 676/303-3;
- the maximum and minimum heat input declared by the manufacturer for the boiler body and for the burner;
- the operation mode for which the boiler body has been designed (on-off, multistage, modulating);
- the flow resistance of the combustion chamber declared by the boiler body manufacturer;
- the type of combustion chamber (direct evacuation or reversed combustion);
- the length (a) of the combustion chamber as indicated in figure 1;
- the diameter or minimum sectional dimension in case of a non circular combustion chamber;
- the burner penetration (x) into the combustion chamber as indicated in figure 1;

## 3.3.2 The installer shall make the following adjustments:

- the heat input, in accordance with the instructions of the manufacturer of the burner;
  - the minimum heat input in case of multistage or modulating burners;
  - the ignition rate of the burner in accordance with the instructions of the manufacturer of the burner;
  - the combustion air
- and shall calculate the global efficiency (Siegert formula).

After the adjustments the installer shall note:

- the heat input;
- the minimum heat input;
- the ignition rate;
- temperature of the combustion products as well as the CO<sub>2</sub> (or O<sub>2</sub>) and CO values These values shall be in accordance with those given by the manufacturer;
- the ambient temperature

Doc. Number	Rev. Number	Approved by GADAC	Approved by WG-GA	Withdrawn
B3	1.1	10/2004	02/2005	

<b>Gas Appliances Directive ( 90/396/EEC )</b>	
<b>GUIDANCE B 4</b>	<b>Approved by WG -GA 06- 2003</b>

**Guideline related to:**

<b>ANNEX</b>	<b>I</b>	<b>Essential requirements</b>
<b>SECTION</b>	<b>2</b>	<b>Materials</b>
<b>PARAGRAPH</b>	<b>2.2.</b>	
<b>SUBJECT</b>	<b>Materials guaranteed</b>	

2.2. The properties of materials that are important for safety must be guaranteed by the manufacturer or the supplier of the appliance. ”

**Question**

For the purposes of EC type-examination what guarantee should be provided by the manufacturer to prove conformity with the Essential Requirement 2.2.?

**Discussion**

The manufacturer is responsible for the choice of the materials, which he judges to be appropriate. During production he checks the materials which are delivered to him on their conformity to the specifications.

The manufacturer has the option to specify that the supplier has to supply materials with a certificate of conformity.

The declaration of the manufacturer is the basis upon which the Notified Body will judge the materials used. The manufacturer guarantees that he will use these materials.

**Conclusion**

The manufacturer’s declaration of the properties of materials in so far as they are important for safety should be part of the technical file.

---0---

*This guidance is for information only; it has no formal status*  
Reference: 90/396/EEC “Gas appliances directive” O.J. L 196, 26.07.90, p. 15  
Source of guidance document: GADAC

<b>Doc. Number</b>	<b>Rev. Number</b>	<b>Approved by GADAC</b>	<b>Approved by WG-GA</b>	<b>Withdrawn</b>
<b>B4</b>	<b>0</b>	<b>06/2003</b>	<b>06/2003</b>	

<b>Gas Appliances Directive ( 90/396/EEC )</b>	
<b>GUIDANCE B 5</b>	<b>Approved by WG -GA 06- 2003</b>

**Guideline related to:**

<b>ANNEX</b>	<b>I</b>	<b>Essential requirements</b>
<b>Section</b>	<b>3</b>	<b>Design and construction</b>
<b>Paragraph</b>	<b>3.1.7.</b>	
<b>Subject</b>	<b>Hazards of electrical origin</b>	

3.1.7. Appliances must be so designed and constructed as to obviate hazards of electrical origin. In the area in which it applies, compliance with the safety objectives in respect of electrical hazards laid down in Directive 73/23/EEC (;) shall be equivalent to fulfilment of this requirement.

**Question**

Is the manufacturers declaration of conformity to Directive 73/23/EEC (Low Voltage Directive – LVD) a sufficient proof of conformity to Essential Requirement 3.1.7.?

**Discussion**

Gas appliances and fittings often include electrical components and parts or are themselves electrical equipment under the LVD Directive.

These components, in case they fall under the scope of Low Voltage Directive, must comply with this Directive when placed on the market and must be CE marked. According to this Directive, the manufacturer’s declaration of conformity is the means to indicate compliance with the requirements of this Directive. This aspect is not to be verified by the Notified Body for the purposes of the GAD.

The manufacturer of the gas appliance or the fitting is responsible for ensuring that these components or other electrical parts are incorporated in a way that ensures the safe functioning of the appliance or fitting. In particular, the manufacturer must pay particular attention to any gas risks that these components and parts may introduce to the appliance. During conformity assessment the Notified Body has to consider such gas related risks of the appliance or fitting.

Products that qualify as gas appliances under the GAD and as electrical equipment under the LVD are subject to manufacturers declaration as regards conformity to the LVD and certification by a Notified Body for the conformity to GAD taking into consideration the above discussion.

**Conclusion**

Directives 90/396/EEC covers also the hazards of electrical origin of gas appliances (or fittings) incorporating electrical components (ER 3.1.7.).

*This guidance is for information only; it has no formal status*

Reference: 90/396/EEC “Gas appliances directive” O.J. L 196, 26.07.90, p. 15

Source of guidance document: GADAC

<b>Doc. Number</b>	<b>Rev. Number</b>	<b>Approved by GADAC</b>	<b>Approved by WG-GA</b>	<b>Withdrawn</b>
<b>B5</b>	<b>0</b>	<b>03/1998</b>	<b>06/2003</b>	

Directives 90/396/EEC and 73/23/EEC apply in a complementary way. For the assessment of the conformity of the electrical components and parts to the requirements of the Directive 73/23/EEC, the Notified Body shall take into account the results of the conformity assessment procedures of the Low Voltage Directive and accept a manufacturer's declaration.

Potential gas risks generated by incorporation or the functioning of such components and parts in gas appliances or fittings are to be assessed under the conformity assessment procedures of the GAD by the Notified Body.

---

*This guidance is for information only; it has no formal status*  
Reference: 90/396/EEC "Gas appliances directive" O.J. L 196, 26.07.90, p. 15  
Source of guidance document: GADAC

<b>Doc. Number</b>	<b>Rev. Number</b>	<b>Approved by GADAC</b>	<b>Approved by WG-GA</b>	<b>Withdrawn</b>
<b>B5</b>	<b>0</b>	<b>03/1998</b>	<b>06/2003</b>	

<b>Gas Appliances Directive ( 90/396/EEC )</b>	
<b>GUIDANCE B 6</b>	<b>Approved by WG -GA 02- 2005</b>

**Guideline related to:**

<b>ANNEX</b>	<b>I</b>	<b>Essential requirements</b>
<b>Section</b>	<b>3</b>	<b>Design and construction</b>
<b>Paragraph</b>	<b>3.1.9.</b>	
<b>Subject</b>	<b>Failure of a safety, controlling or regulating device</b>	

3.1.9. Appliances must be so designed and constructed that failure of a safety, controlling or regulating device may not lead to an unsafe situation.”

**Question**

In modern appliances it frequently happens that an electronic reset device is applied to reset the appliance from volatile or non-volatile lock-out. Such a device can be for example an electronic room thermostat or a control board in the appliance itself.

What are the necessary safety requirements for the use of such reset devices?

**Discussion**

Resetting an appliance from lock-out is a safety relevant action. Therefore preventions shall be taken against unintended resetting. Due to the rather rare occurrence of mains interruptions in case of volatile lock-out it is allowed to reset the appliance by interrupting the mains. In case of non-volatile lock-out a manual reset on the appliance is required. Unintended reset action is not allowed at all (even in the case of tampering or misuse of the reset device).

If a simple reset device (a switch) is replaced by an electronic one, e.g. a room thermostat with a reset provision, an analysis has to be made of the failure modes of the signal output and input. In case of using a burner control system as resetting device, which is complying with the relevant standard, internal failures resulting into a static output signal, are no problem. They can be compared with stuck-at failures of a conventional reset device. An approved system will not react on this.

However dynamic output signals resulting from internal faults, e.g. in case of a malfunctioning program-counter, cannot be excluded. Such a dynamic signal will continuously reset the appliance, which is not acceptable. An electronic reset device should meet the requirements of internal failure behaviour

It is also that the judgement of the behaviour of the reset device shall be independent from the application: no gas appliance shall be subjected to unintended resets, even not under fault conditions.

*This guidance is for information only; it has no formal status*

Reference: 90/396/EEC “Gas appliances directive” O.J. L 196, 26.07.90, p. 15

Source of guidance document: GADAC

<b>Doc. Number</b>	<b>Rev. Number</b>	<b>Approved by GADAC</b>	<b>Approved by WG-GA</b>	<b>Withdrawn</b>
<b>B6</b>	<b>0</b>	<b>10/2000</b>	<b>06/2003</b>	



Furthermore, when establishing the internal fault behaviour of a reset device it is not required to apply a two-fault criterion. The application of the single fault criterion, e.g. as described in EN 60730-1 (CENELEC), can be considered as being sufficient.

**Conclusion**

Those electronic parts of the device, which are involved in a reset action shall meet the necessary safety requirements as laid down in the relevant requirements for the appliance or fitting. The application of the single fault criterion, e.g. as described in EN 60730-1 (CENELEC), can be considered as being sufficient.

---

*This guidance is for information only; it has no formal status*  
Reference: 90/396/EEC “Gas appliances directive” O.J. L 196, 26.07.90, p. 15  
Source of guidance document: GADAC

<b>Doc. Number</b>	<b>Rev. Number</b>	<b>Approved by GADAC</b>	<b>Approved by WG-GA</b>	<b>Withdrawn</b>
<b>B6</b>	<b>0</b>	<b>10/2000</b>	<b>06/2003</b>	

<b>Gas Appliances Directive ( 90/396/EEC )</b>	
<b>GUIDANCE B 7</b>	<b>Approved by WG -GA 02/2005</b>

**Guideline related to:**

<b>ANNEX</b>	<b>I</b>	<b>Essential requirements</b>
<b>Section</b>	<b>3</b>	<b>Design and construction</b>
<b>Paragraph</b>	<b>3.2.3.</b>	
<b>Subject</b>	<b>Unburned gas release</b>	

3.2.3. Appliances intended to be used in indoor spaces and rooms must be fitted with a special device which avoids a dangerous accumulation of unburned gas in such spaces or rooms.

Appliances which are not fitted with such devices must be used only in areas where there is sufficient ventilation to avoid a dangerous accumulation of unburned gas.

Member States may define on their territory adequate space ventilation conditions for the installation of such appliances, bearing in mind the features peculiar to them.

Large-scale kitchen appliances and appliances powered by gas containing toxic components must be equipped with the aforesaid device.

**This Guidance Sheet has been withdrawn**

---0---

Doc. Number	Rev. Number	Approved by GADAC	Approved by WG-GA	Withdrawn
B7	1	---	02/2005	02/2008

<b>Gas Appliances Directive ( 90/396/EEC )</b>	
<b>GUIDANCE B 8</b>	<b>Approved by WG -GA 06- 2003</b>

**Guideline related to:**

<b>ANNEX</b>	<b>I</b>	<b>Essential requirements</b>
<b>Section</b>	<b>3</b>	<b>Design and construction</b>
<b>Paragraph</b>	<b>3.3. &amp; 3.4.1.</b>	
<b>Subject</b>	<b>Ignition and combustion</b>	

<p>3.3. Ignition Appliances must be so constructed that, when used normally:</p> <ul style="list-style-type: none"> <li>- ignition and re-ignition is smooth,</li> <li>- cross-lighting is assured.</li> </ul> <p>3.4. Combustion 3.4.1. Appliances must be so constructed that, when used normally, flame stability is assured and combustion products do not contain unacceptable concentrations of substances harmful to health.</p>
---

**Question**

When testing gas appliances what consideration shall be given to external influences which may affect ignition and combustion?

**Discussion**

In these Essential Requirements reference is made to the term “normally used”. Article 1.4. of the Directive defines what is intended by this term. For the application of these Essential Requirements the last two indents are particularly important:

- *used with a normal variation in the gas quality and a normal fluctuation in the supply pressure, and*
- *used in accordance with its intended purpose or in any way which can be reasonably foreseen.*

*This guidance is for information only; it has no formal status*

Reference: 90/396/EEC “Gas appliances directive” O.J. L 196, 26.07.90, p. 15

Source of guidance document: GADAC

<b>Doc. Number</b>	<b>Rev. Number</b>	<b>Approved by GADAC</b>	<b>Approved by WG-GA</b>	<b>Withdrawn</b>
<b>B8</b>	<b>0</b>	<b>06/2003</b>	<b>06/2003</b>	

This means that in response to the first indent above only the tests for ignition and combustion should be carried out with variations in the gas quality and pressure of the distribution gas. For many years in the gas industry these variations have been simulated by the application of a system using limit gases and limit pressures.

The implication of the second indent above is that for those tests with the limit gases and pressure has to be added also tests in situations that can be reasonably foreseen. Such specific situations include:

- a) Variations in the auxiliary energy, or
- b) Variation in the chimney conditions, or
- c) With room draughts.

### **Conclusion**

Testing should be carried out under the following conditions:

A) Reference conditions

- Ignition, cross-lighting and re-ignition (ER 3.3.) with the relevant limits of gas quality(ies) and pressure(s) in accordance with the category(ies) chosen by the manufacturer, and
- Combustion characteristics (ER 3.4.1.) with the relevant limits of gas quality(ies) and pressure(s) in accordance with the category(ies) chosen by the manufacturer.

B) External influences

Under variation of draught conditions (chimney, room or wind) or with variations of auxiliary energy or other external influences on the appliance

- for the ignition, cross-lighting and re-ignition (ER 3.3.) and
- for the combustion characteristics (ER 3.4.1.)

with, for these conditions, the relevant gas quality(ies) and pressure(s) in accordance with the category(ies) chosen by the manufacturer.

The above interprets the meaning of “normally used” as applied in the Essential Requirements following the definition given in Article 1.4. of the Directive.

---0---

*This guidance is for information only; it has no formal status*

Reference: 90/396/EEC “Gas appliances directive” O.J. L 196, 26.07.90, p. 15

Source of guidance document: GADAC

<b>Doc. Number</b>	<b>Rev. Number</b>	<b>Approved by GADAC</b>	<b>Approved by WG-GA</b>	<b>Withdrawn</b>
<b>B8</b>	<b>0</b>	<b>06/2003</b>	<b>06/2003</b>	

<b>PAGES</b>	<b>1-2</b>	
<b>ANNEX</b>	<b>I</b>	<b>Essential requirements</b>
<b>SECTION</b>	<b>3</b>	<b>Design and construction</b>
<b>PARAGRAPH</b>	<b>3.4.3</b>	
<b>SUBJECT</b>	<b>Combustion</b>	

*“Appliances connected to a flue for the dispersal of combustion products must be so constructed that in abnormal draught conditions there is no release of combustion products in a dangerous quantity into the room concerned.”*

### **Question**

Does this requirement mean that a special safety device must be incorporated into the appliances and will there be conditions, where this safety device is not needed, since release of combustion products does not create a dangerous situation?

### **Discussion**

The essential requirement is referring to the design of the appliances, connected to a flue in a way where there can be possibilities that a release of combustion products into the room can occur in the event of blockage of the flue or as result of down draught of the combustion products in the flue.

If these appliances are installed in a room i.e. occupied areas, these appliances must be fitted with safety devices (e.g. a TTB), which close the gas supply to the burners in case of release of combustion products into the room, since these conditions will create a risk of CO poisoning of persons in the house or flat.

However, appliances might be installed in locations, where the release of combustion products cannot build up a CO concentration in the room which will be dangerous to persons.

Such types of installations can be installation of appliances in very big rooms or in rooms, where the ventilation will assure that the release of combustion products cannot affect persons under normal or foreseeable situations.

The following types of installations are not considered to give rise to a dangerous quantity:

1. Boilers in boiler rooms, which are specifically designed to maintain the provision of an adequate level of controlled ventilation and to which it is not usual that persons, other than authorised persons, have access.
2. Overhead radiant heaters which are installed at such a height relative to the persons who may be exposed to combustion products that natural dilution ventilation would prevent the build-up of a dangerous quantity.

*This guidance is for information only; it has no formal status*

Reference: 90/396/EEC “Gas appliances directive” O.J. L 196, 26.07.90, p. 15

Source of guidance document: GADAC

Doc. Number	Rev. Number	Approved by GADAC	Approved by WG-GA	Withdrawn
B9	0.1	6/2003	6/2003	

**Conclusion**

Installation of appliances with an open flue in normal rooms in houses or flats will require a safety device incorporated into the appliances.

However, there will be examples as indicated or types of installations, where these safety devices will not be needed, since a dangerous situation will not occur.

---

---

*This guidance is for information only; it has no formal status*

Reference: 90/396/EEC "Gas appliances directive" O.J. L 196, 26.07.90, p. 15

Source of guidance document: GADAC

Doc. Number	Rev. Number	Approved by GADAC	Approved by WG-GA	Withdrawn
B9	0.1	6/2003	6/2003	

<b>Gas Appliances Directive ( 90/396/EEC )</b>	
<b>GUIDANCE B 10</b>	<b>Approved by WG -GA 06- 2003</b>

**Guideline related to:**

<b>ANNEX</b>	<b>I</b>	<b>Essential requirements</b>
<b>Section</b>	<b>3</b>	<b>Design and construction</b>
<b>Paragraph</b>	<b>3.4.3.</b>	
<b>Subject</b>	<b>Prevention of the release of combustion products in abnormal draught conditions</b>	

3.4. Combustion

.....

3.4.3. Appliances connected to a flue for the dispersal of combustion products must be so constructed that in abnormal draught conditions there is no release of combustion products in a dangerous quantity into the room concerned.

**Question**

In many appliances an electronic combustion discharge device (TTB) is used to guard against the release of combustion products into occupied areas.

What requirements should be set on electronic TTBs?

**Discussion**

Combustion products can be extremely dangerous.

In the case of a safety action, the TTB shall cause a (non-volatile) lock-out or a shut-down for at least 10 minutes <sup>(1)</sup>. Due to their construction and their connection directly in series with the gas valve conventional TTBs normally comply with these requirements.

In the case of electronic TTBs, similar requirements shall apply. Open and short circuit of the sensing element shall be detected or be proven impossible. If the waiting time is generated by electronics, the electronics should be fault tolerant. Concerning the temperature switching level the electronics including the sensing element should be fault tolerant as well.

**Conclusion**

When an electronic TTB is subject to a single fault the appliance shall remain safe. The failure in the TTB shall either leave the TTB functioning correctly or shall cause the appliance to be shut down.

A relevant standard for these TTBs is EN 60730-2-9.

---

<sup>(1)</sup> *This is the generally accepted waiting time to avoid false operation.*

*This guidance is for information only; it has no formal status*

Reference: 90/396/EEC "Gas appliances directive" O.J. L 196, 26.07.90, p. 15

Source of guidance document: GADAC

<b>Doc. Number</b>	<b>Rev. Number</b>	<b>Approved by GADAC</b>	<b>Approved by WG-GA</b>	<b>Withdrawn</b>
<b>B10</b>	<b>0</b>	<b>06/2003</b>	<b>06/2003</b>	

<b>Gas Appliances Directive ( 90/396/EEC )</b>	
<b>GUIDANCE B 11</b>	<b>Approved by WG -GA 06- 2003</b>

**Guideline related to:**

<b>ANNEX</b>	<b>I</b>	<b>Essential requirements</b>
<b>Section</b>	<b>3</b>	<b>Design and construction</b>
<b>Paragraph</b>	<b>3. 5.</b>	
<b>Subject</b>	<b>Rational use of energy, state of the art</b>	

3.5. Appliances must be so constructed as to ensure rational use of energy, reflecting the state of the art and taking into account safety aspects.

**Question**

How can the manufacturer demonstrate compliance with ER 3.5.?

**Discussion**

The objective of the directive is to introduce a sound balance between rational use of energy on the one hand and safety aspects on the other hand. This requirement must be applied with discernment, to take account of the state of the art. However, for products with an important energy consumption, requirements have been laid down by Community legislation i.e. boilers with heat input 4 kW - 400 kW, which shall satisfy the requirements of the Directive 92/42/EEC. For other products, the *state of the art*<sup>(1)</sup> has to be taken into consideration. Guidance on the state of the art can be found in the relevant harmonised European standards giving the presumption of conformity. Where no harmonised standards exist, other standards likely to reflect the state of the art can be used as a basis for assessment.

**Conclusion**

*Boilers with heat input 4 kW - 400 kW:*

These boilers shall satisfy the requirements of the Directive 92/42/EEC.

*All other appliances:*

Guidance on the state of the art can be found in the relevant harmonised European standards giving the presumption of conformity. Where no harmonised standards exist, other standards likely to reflect the state of the art can be used as a basis for assessment.

----

<sup>(1)</sup> EN 45020: “Developed stage of technical capability at a given time as regards products, processes and services, based on the relevant consolidated findings of science, technology and experience”.

*This guidance is for information only; it has no formal status*

Reference: 90/396/EEC “Gas appliances directive” O.J. L 196, 26.07.90, p. 15

Source of guidance document: GADAC

<b>Doc. Number</b>	<b>Rev. Number</b>	<b>Approved by GADAC</b>	<b>Approved by WG-GA</b>	<b>Withdrawn</b>
<b>B 11</b>	<b>0</b>	<b>06/1996</b>	<b>06/2003</b>	



<b>Gas Appliances Directive ( 90/396/EEC )</b>	
<b>GUIDANCE B 12</b>	<b>Approved by WG -GA 02- 2005</b>

**Guideline related to:**

<b>ANNEX</b>	<b>I</b>	<b>Essential requirements</b>
<b>Section</b>	<b>3</b>	<b>Design and construction</b>
<b>Paragraph</b>	<b>3.1.9. and 3.1.12.</b>	
<b>Subject</b>	<b>Remote controls for gas fires</b>	

3.1.9. Appliances must be so designed and constructed that failure of a safety, controlling or regulating device may not lead to an unsafe situation.

and

3.1.12. Levers and other controlling and setting devices must be clearly marked and give appropriate instructions so as to prevent any error in handling. Their design must be such as to preclude accidental manipulation.”

**Question**

How should these provisions be applied with respect to remote controls for gas fires?

**Note:** A “*gas fire*” is understood to be an independent space heater for directly heating the area of the dwelling in which it is installed. It can be open or closed fronted, having an open fire or hot surfaces respectively, presenting a potential risk in case of unintended operation.

**Discussion**

Use of remote controls can give rise to unsafe situations through accidental manipulation, component fault or external uncontrolled influences.

For example:

1. If the control is capable of operation by a small child who is unable to operate the gas fire with the normal manual control device.
2. If the gas fire is inadvertently turned on with a combustible object or objects placed too close to the gas fire.
3. If the remote controlling device is capable of operating another gas fire in the same room, in another room or in another house at the same time.
4. If the gas fire, in standby mode, comes into operation, due to EMC phenomena under abnormal conditions.
5. If the gas fire, in standby mode, comes into operation, due to electrical faults (e.g. wiring faults) or component faults (random faults).

Different solutions may have to be adopted in order to control these risks.

*This guidance is for information only; it has no formal status*

Reference: 90/396/EEC “Gas appliances directive” O.J. L 196, 26.07.90, p. 15

Source of guidance document: GADAC

<b>Doc. Number</b>	<b>Rev. Number</b>	<b>Approved by GADAC</b>	<b>Approved by WG-GA</b>	<b>Withdrawn</b>
<b>B12</b>	<b>1</b>	<b>10/2004</b>	<b>02/2005</b>	

## **Conclusion**

To prevent accidental manipulation, instructions alone are not an adequate solution.

*To address examples 1 and 2:*

Design related solutions shall be adopted in order to ensure that the turning on can only be done by a responsible deliberate act (e.g. two buttons to be activated).

*To address examples 2 and 3:*

In order to prevent a remote controlling device operating another gas fire in the same room, in another room or in another house at the same time, the following measures shall be taken:

- it shall not be possible to achieve ignition of the main burner of the gas fire when the appliance is unattended, and
- the control or the receiver shall be designed such that, or be capable of being programmed either by the gas fire manufacturer or the installer such that, the risk of two gas fires being accidentally activated simultaneously is prevented.

Note: *Unattended to be defined as “the gas fire is not visible to the operator of the controlling device”.*

*To address example 4:*

To prevent a gas fire, in standby mode, coming into operation due to EMC phenomena, the appliance, including the remote controlling device, shall comply with immunity requirements e.g. as described in EN 50165 clauses 19.101.4 – 19.101.8 (at level 2 and 3).

*To address example 5:*

To prevent a gas fire, in standby mode, coming into operation due to electrical faults (e.g. wiring faults) or component faults (random faults), the appliance, when in standby mode:

1. shall not come into operation due to a single electrical fault (see: EN 60335-1);
2. shall not come into operation due to a failure of a single electronic component (see: EN 60730-1, single fault criterion, for parts of the electronics that can cause this situation).

*To address example 2:*

A means of isolating the gas fire from the gas supply shall either be incorporated in the appliance, or the technical instructions for the installer shall require a means of isolation to be incorporated into the installation close to the appliance.

---0---

*This guidance is for information only; it has no formal status*

Reference: 90/396/EEC “Gas appliances directive” O.J. L 196, 26.07.90, p. 15

Source of guidance document: GADAC

<b>Doc. Number</b>	<b>Rev. Number</b>	<b>Approved by GADAC</b>	<b>Approved by WG-GA</b>	<b>Withdrawn</b>
<b>B12</b>	<b>1</b>	<b>10/2004</b>	<b>02/2005</b>	

<b>Gas Appliances Directive ( 90/936/EEC )</b>	
<b>GUIDANCE B13</b>	<b>Approved by WG-GA 03-2009</b>

**Guidance related to:**

<b>ANNEX</b>	<b>I</b>	<b>Essential requirements</b>
<b>Section</b>	<b>1</b>	<b>General conditions</b>
<b>Paragraph</b>	<b>1.2</b>	
<b>Subject</b>	<b>Electronic distribution of instructions and manuals (through the internet or by CD/DVD)</b>	

1.2 When placed on the market, all appliances must:

- be accompanied by technical instructions intended for the installer,
- be accompanied by instructions for use and servicing, intended for the user,
- bear appropriate warning notices, which must also appear on the packaging.

The instructions and warning notices must be in the official language or languages of the Member States of destination.

**Questions**

1. Is it allowed for the manufacturer to use internet for the distribution to the installer and/or user of the following documents:
  - a. technical instructions, intended for the installer
  - b. instructions for use and servicing, intended for the user?
2. Is it allowed for the manufacturer to make the above mentioned instructions available to the installer and/or user on a CD or DVD, delivered together with the appliance?

**Discussion**

The manufacturer has to market his appliances together with the instructions for installation, use and servicing in the various languages of the countries of destination. For logistics reasons it would be very convenient for the manufacturer not to be obliged to supply hard copies of these instructions with every appliance, but to make these instructions available through internet or to supply the appliances/fittings with a CD/DVD containing the several language versions of the instructions.

If the documents are available only by downloading them from internet, the appliance/fitting is not accompanied by these documents as is obligatory according to Annex I, par. 1.2.

It is assumed that the aim of the provision of Annex I, par.1.2 is to have the complete instructions available at the place of installation and use, thus ensuring as much as possible that all instructions will be taken into account.

*This guidance is for information only; it has no formal status*

Reference: 90/396/EEC "Gas appliances directive" O.J. L 196, 26.07.90, p. 15

Source of guidance document: GADAC

Doc. number	Rev. number	Approved by GADAC	Approved by WG-GA	Withdrawn
B13	-	10/2008	03-2009	

A reading of the instructions from the screen of the PC, possibly not available at the place of installation/use, may lead to omissions.

The manufacturer can not be sure that every installer and user have at their disposal a PC with an internet connection and will download and print the instructions.

Moreover, finding the manual belonging to the appliance/fitting in the language(s) of the country of destination can be complex, especially when the type of appliance/fitting is a member out of a large family.

Making the instructions available on a CD/DVD, supplied together with the appliance, may formally comply with the provision of Annex I, par. 1.2, but can not be considered to meet the aim of this provision. As stated above, the manufacturer can not be sure that the installer/user has the means to download the instructions from the CD/DVD and whether or not he can or will print them out.

For fittings, marketed by the manufacturer directly to an appliance manufacturer for incorporation in appliances, this subject is dealt with in Annex I, par. 1.3.

## Conclusion

According to the GAD Annex I, par. 1.2, hard copies of the instructions for installation, use and servicing shall be provided with the appliance.

Distribution of the instructions for installation, use and servicing through internet or by a CD/DVD, without providing together with the appliance/fitting hard copies of these instructions in the appropriate language(s), is not complying with the provisions of Annex I, par. 1.2.

----

Doc. number	Rev. number	Approved by GADAC	Approved by WG-GA	Withdrawn
B13	-	10/2008	03-2009	

<b>Gas Appliances Directive ( 90/396/EEC )</b>	
<b>GUIDANCE C 1</b>	<b>Approved by WG -GA 06- 2003</b>

**Guideline related to:**

<b>ANNEX</b>	<b>II</b>	<b>Procedure for certification of conformity</b>
<b>Section</b>	<b>1</b>	<b>EC type-examination</b>
<b>Paragraph</b>	<b>1.3.2. and 1.3.3.</b>	
<b>Subject</b>	<b>Acceptance of manufacturers test results</b>	

<p>1.3. The notified body must: ....</p> <p>1.3.2. perform, or have performed, the appropriate examinations and/or tests to check whether the solutions adopted by the manufacturer meet the essential requirements where the standards referred to in Article 5 have not been applied;</p> <p>1.3.3. perform, or have performed, the appropriate examinations and/or tests to check whether the applicable standards have effectively been applied where the manufacturer has chosen to do so, thereby assuring conformity with the essential requirements.</p>
--

**Question**

Can the Notified Body accept, as the basis for certification, the results of testing carried out in a manufacturer's laboratory?

**Discussion**

The manufacturer's application for type-examination must include among other things the design documentation that must contain for instance test reports.

The Notified Body must check and certify that an appliance, representative of the production envisaged, meets the provisions of the Directive which apply to it. As part of this work the design documentation is subject to direct assessment by the Notified Body.

**Conclusion**

Yes.

However, the Notified Body, in using the manufacturers test results, has to verify that all relevant criteria have been met.

-----

*This guidance is for information only; it has no formal status*

Reference: 90/396/EEC "Gas appliances directive" O.J. L 196, 26.07.90, p. 15

Source of guidance document: GADAC

<b>Doc. Number</b>	<b>Rev. Number</b>	<b>Approved by GADAC</b>	<b>Approved by WG-GA</b>	<b>Withdrawn</b>
<b>C1</b>	<b>0</b>	<b>06/2003</b>	<b>06/2003</b>	

<b>Gas Appliances Directive ( 90/396/EEC )</b>	
<b>GUIDANCE C 2</b>	<b>Approved by WG -GA 06- 2003</b>

**Guideline related to:**

<b>ANNEX</b>	<b>II</b>	<b>Procedure for certification of conformity</b>
<b>Section</b>	<b>2</b>	<b>EC declaration of conformity to type</b>
<b>Paragraph</b>	<b>2.3.</b>	
<b>Subject</b>	<b>On-site checks</b>	

2.3. On-site checks of appliances must be undertaken at random by the notified body at intervals of one year or less. An adequate number of appliances must be examined and appropriate tests as set out in the applicable standards referred to in Article 5 or equivalent tests must be carried out in order to ensure conformity with the corresponding essential requirements of this Directive. The notified body shall in each case determine whether these tests need to be carried out in full or in part. Where one or more appliances are rejected, the notified body shall take the appropriate measures to prevent the marketing thereof.

**Question**

What measures should the Notified Body take in case where tests to 2.3. of ANNEX II reveal non-conformity?

**Discussion**

When the Notified Body identifies a non-conformity in the meaning of point 2.3., it will enter into discussion with the manufacturer to solve the identified non compliance. In case the non-conformity to the type persists, it can formally suspend the surveillance activities, thus impeding the manufacturer from affixing the CE marking and from placing the product on the market. It will inform, in such a case, the other Notified Bodies. It will also draw the attention of the manufacturer to the potential consequences for the products already placed on the market. The Notified Body can, as appropriate, in the light of the safety risks identified, inform the competent market surveillance authorities.

The Notified Body cannot oblige the manufacturer to have previously manufactured appliances removed from the market. Such a measure is to the competence of the enforcement authority only (see Article 7) who will have been informed by the Notified Body as mentioned above.

**Conclusion**

When an on-site check reveals non-conformity of one or more appliances or fittings, the Notified Body in charge of it should take the measures described above.

---0---

*This guidance is for information only; it has no formal status*

Reference: 90/396/EEC "Gas appliances directive" O.J. L 196, 26.07.90, p. 15

Source of guidance document: GADAC

<b>Doc. Number</b>	<b>Rev. Number</b>	<b>Approved by GADAC</b>	<b>Approved by WG-GA</b>	<b>Withdrawn</b>
<b>C2</b>	<b>0</b>	<b>06/2003</b>	<b>06/2003</b>	

<b>Gas Appliances Directive ( 90/396/EEC )</b>	
<b>GUIDANCE C 3</b>	<b>Approved by WG -GA 02- 2005</b>

**Guideline related to:**

<b>ANNEX</b>	<b>II</b>	<b>Procedure for certification of conformity</b>
<b>Section</b>	<b>2</b>	<b>EC declaration of conformity to type</b>
<b>Paragraph</b>	<b>2.3.</b>	
<b>Subject</b>	<b>On-site checks surveillance</b>	

2.3. On-site checks of appliances must be undertaken at random by the notified body at intervals of one year or less. An adequate number of appliances must be examined and appropriate tests as set out in the applicable standards referred to in Article 5 or equivalent tests must be carried out in order to ensure conformity with the corresponding essential requirements of this Directive. The notified body shall in each case determine whether these tests need to be carried out in full or in part. Where one or more appliances are rejected, the notified body shall take the appropriate measures to prevent the marketing thereof.

**Question**

How should on-site checks of gas appliances and fittings be organised in order to ensure compliance?

**Discussion**

Both the manufacturer and the Notified Body have obligations. The manufacturer shall assure access for the chosen Notified Body to the CE type-examination and related test report and design documentation and must ensure the provision of facilities for the inspection of his products, produced and CE marked under the responsibility of the Notified Body.

The Notified Body may take account of the existence of a manufacturer's quality system with the view to reduce the extent of the inspection. Under these circumstances the Notified Body shall have access to the production line. It shall verify the tests and quality system elements performed by the manufacturer, to achieve conformity with the type.

The Notified Body can at all times, at least once a year, visit the warehouses of the manufacturer or the warehouse of his appointed representative to take one or more samples of the products registered with the Notified Body from a sufficiently representative quantity and on the basis of inspection sheets, test reports and check lists insofar as such exist, to compare whether the samples comply with the type as described in the EC type-examination certificate and with the Essential Requirements of the gas appliance Directive. The manufacturer or his appointed representative shall provide the necessary support.

*This guidance is for information only; it has no formal status*

Reference: 90/396/EEC "Gas appliances directive" O.J. L 196, 26.07.90, p. 15

Source of guidance document: GADAC

<b>Doc. Number</b>	<b>Rev. Number</b>	<b>Approved by GADAC</b>	<b>Approved by WG-GA</b>	<b>Withdrawn</b>
<b>C3</b>	<b>1</b>	<b>10/2004</b>	<b>02/2005</b>	

If the Notified Body is of the opinion that a product must be submitted to inspection test, and also that the inspection cannot be carried out with in-house test equipment, the products which he selects and marks (e.g. with a lead seal) shall be sent to a test laboratory specified by the Notified Body.

The amount of the verification work from the Notified Body shall be concentrated upon verification of critical points, which characterize the safety of the appliance and thereby fulfil the Essential Requirements of the Directive.

The verification of critical points implies that test of the final products is carried out for principal controls.

In the Annex are given the list of principal controls, which cover the majority of current gas appliances.

Nevertheless some special appliances may be subject to other requirements with regard to a different technology or design. In such a case the Notified Body shall determine the complementary test. Equally, for certain designs some of the following principal controls may not apply.

The manufacturer has to take all necessary measures to ensure that the manufacturing process results in conformity of appliances with the Essential Requirements of the above-mentioned Directive. He may carry out the under mentioned principal controls, foremost at the end stage of the production and in an adequate way regarding his own manufacturing methods and facilities.

The Notified Body must verify the correct result of the principal controls by assuring the documentation and by taking individual responsibilities for issuing a certificate of conformity as a result of the surveillance and considers the under mentioned principal controls as a basis for confirming the conformity of the gas appliance.

According to the procedures for certification of conformity (Annex II of GAD) the Notified Body may perform further appropriate examinations and determine whether these tests need to be performed in full or in part to ensure the conformity of the products with the type. In doing so it applies its own methods and procedures and may have informed the manufacturer thereof in advance.

### **Conclusion**

The Notified Body may take account of all activities, initiated by the manufacturer's to assure conformity with the CE type-examination certificate, but must assure that all relevant principal controls are carried out on the basis of the list, as the example given in Annex.

./..

<b>Doc. Number</b>	<b>Rev. Number</b>	<b>Approved by GADAC</b>	<b>Approved by WG-GA</b>	<b>Withdrawn</b>
<b>C3</b>	<b>1</b>	<b>10/2004</b>	<b>02/2005</b>	



**List of principal controls (tests on the final Product)**

1. Leakage rate of the components conveying gas (inside and outside)
2. Nominal flow rates and nominal heat input
3. Leakage rate of the components conveying water
4. Working appliance:
  - ignition
  - burners
  - auxiliary equipment and fittings
  - safety ignition devices and flame monitoring
5. Components (shut-off valves, thermostats,...)
6. Combustion:
  - flame stability
  - combustion quality
  - critical emission limits (CO, CO<sub>2</sub>)
  - tightness of the exhaust gas extraction system
  - tightness of the combustion circuit in type B/C appliances
  - exhaust gas monitor
  - atmosphere monitor
7. Efficiency
8. Safety and regulating systems (governors)
9. Surface temperatures
10. Electrical tests covered by the Low Voltage Directive
  - special electrical test may be required
  - recommendation for tests relating to (CENELEC EN 50106)
    - earthing continuity
    - dielectric strength

NOTE : *The manufacturer has to assure proof of the compliance with the safety objectives of electrical hazards laid down in the Low Voltage Directive (73/23/EEC).*

./..

*This guidance is for information only; it has no formal status*  
 Reference: 90/396/EEC "Gas appliances directive" O.J. L 196, 26.07.90, p. 15  
 Source of guidance document: GADAC

Doc. Number	Rev. Number	Approved by GADAC	Approved by WG-GA	Withdrawn
C3	1	10/2004	02/2005	

### Examples of models for verification by the Notified Body

Type of Inspections	Requirements to Subcontractors	Continuous control during production	End stage Control
<b>1. Internal and External leakage rate</b>			
Model 1		+ (100%)	
Model 2			+ (100 %)
<b>2. Nominal Heat input</b>			
Model 1	+ SPC		+ (spot check)
Model 2		+ (100%)	
Model 3		+ SPC	+ (spot check)
<b>3. Leakage rate of water circuit</b>			
Model 1	+ (100 %)		
Model 2		+ (100%)	
Model 3			+ (100 %)
<b>4. Appliance operation</b>			
			+ (100 %)
<b>5. Components</b>			
Model 1	+ SPL		+ (spot check)
Model 2		+ (100%)	
Model 3			+ (100 %)
<b>6. Combustion</b>			
6.1 Flame stability			+ (100 %)
6.2 Combustion quality			+ (spot check)
6.3 Soundness of combustion circuit			+ (spot check)
6.4 Safety components			+ (100 %)
<b>7. Efficiency</b>			
			+ (spot check)
<b>8. Electrical Safety</b>			
Model 1	+ SPC		+ (spot check)
Model 2		+ (100%)	
<b>9. Surface temperatures</b>			
			+ (spot check)

SPC = Statistical Process Control

---0---

*This guidance is for information only; it has no formal status*  
Reference: 90/396/EEC "Gas appliances directive" O.J. L 196, 26.07.90, p. 15  
Source of guidance document: GADAC

Doc. Number	Rev. Number	Approved by GADAC	Approved by WG-GA	Withdrawn
C3	1	10/2004	02/2005	

<b>Gas Appliances Directive ( 90/396/EEC )</b>	
<b>GUIDANCE C 4</b>	<b>Approved by WG -GA 06- 2003</b>

**Guideline related to:**

<b>ANNEX</b>	<b>II</b>	<b>Procedure for certification of conformity</b>
<b>Section</b>	<b>3 &amp; 4</b>	<b>EC declaration of conformity to type</b> (guarantee of production / product quality)
<b>Paragraph</b>	<b>3.3.3. &amp; 4.3.3.</b>	
<b>Subject</b>	<b>Quality System</b>	

3.3.3. The notified body shall examine and evaluate the quality system to determine whether it satisfies the requirements referred to in point 3.3.2. It will presume conformity with these requirements in respect of quality systems that implement the corresponding harmonized standard.

It must notify its decision to the manufacturer and inform the other notified bodies thereof. The notification to the manufacturer must contain the conclusions of the examination, the name and address of the notified body and the reasoned assessment decision in respect of the appliances concerned.

.....  
and

4.3.3. The notified body shall examine and evaluate the quality system to determine whether it satisfies the requirements referred to in point 4.3.2. It will presume conformity with these requirements in respect of quality systems that implement the corresponding harmonized standard. It must notify the manufacturer of its decision and inform the other notified bodies thereof. The notification to the manufacturer must contain the conclusions of the examination, the name and address of the notified body and the reasoned assessment decision for the appliances concerned.

**Question**

Is certification to EN ISO 9001, 9002 or 9003 obligatory to meet the requirements of sections 3 and 4 of Annex II?

**Conclusion**

No.

**Question 2**

Can a manufacturer having a certificated EN ISO 9001, 9002, 9003 quality management system be considered satisfying ANNEX II paragraphs 3.3.3. and 4.3.3. of GAD?

**Discussion**

A quality management system satisfying the requirements of EN ISO 9000 series may satisfy the requirements of the factory production control system specified by the Directive.

./..

*This guidance is for information only; it has no formal status*

Reference: 90/396/EEC "Gas appliances directive" O.J. L 196, 26.07.90, p. 15

Source of guidance document: GADAC

<b>Doc. Number</b>	<b>Rev. Number</b>	<b>Approved by GADAC</b>	<b>Approved by WG-GA</b>	<b>Withdrawn</b>
<b>C4</b>	<b>0</b>	<b>06/1996</b>	<b>06/2003</b>	

An EN ISO 9000 series certificate issued by an assessment body recognised by the Notified Body may be taken into account by the Notified Body when undertaking the assessment of the factory production relating to the specific types of products detailed in the EC type-examination certificate.

### **Conclusion**

No, but EN ISO 9001, 9002, 9003 may be used partly or to full extent depending on the stated scope of EN ISO 9001, 9002, 9003. The EN ISO certificate should include as a minimum, those product types for which the manufacturer seeks approval under GAD for the factory production control system.

However, technical aspects relating to type conformity and the specific factory product control procedures pertaining to the manufacture of the product type must be inspected and assessed by a Notified Body for compliance to the GAD.

---

*This guidance is for information only; it has no formal status*

Reference: 90/396/EEC "Gas appliances directive" O.J. L 196, 26.07.90, p. 15

Source of guidance document: GADAC

<b>Doc. Number</b>	<b>Rev. Number</b>	<b>Approved by GADAC</b>	<b>Approved by WG-GA</b>	<b>Withdrawn</b>
<b>C4</b>	<b>0</b>	<b>06/1996</b>	<b>06/2003</b>	

<b>Gas Appliances Directive ( 90/396/EEC )</b>	
<b>GUIDANCE C 5</b>	<b>Approved by WG -GA</b> <b>06- 2003</b>

**Guideline related to:**

<b>ANNEX</b>	<b>II</b>	<b>Procedure for certification of conformity</b>
<b>Section</b>	<b>3 &amp; 4</b>	<b>EC declaration of conformity to type</b> (guarantee of production / product quality)
<b>Paragraph</b>	<b>3.3.3. &amp; 4.3.3.</b>	
<b>Subject</b>	<b>Examination and evaluation of the quality system</b>	

3.3.3. The notified body shall examine and evaluate the quality system to determine whether it satisfies the requirements referred to in point 3.3.2. It will presume conformity with these requirements in respect of quality systems that implement the corresponding harmonized standard.  
It must notify its decision to the manufacturer and inform the other notified bodies thereof. The notification to the manufacturer must contain the conclusions of the examination, the name and address of the notified body and the reasoned assessment decision in respect of the appliances concerned.

.....  
and

4.3.3. The notified body shall examine and evaluate the quality system to determine whether it satisfies the requirements referred to in point 4.3.2. It will presume conformity with these requirements in respect of quality systems that implement the corresponding harmonized standard. It must notify the manufacturer of its decision and inform the other notified bodies thereof. The notification to the manufacturer must contain the conclusions of the examination, the name and address of the notified body and the reasoned assessment decision for the appliances concerned.

**Question**

How should the examination and evaluation of the quality system for production of gas appliances and fittings be carried out?

**Discussion**

Both the manufacturer and the Notified Body have roles to play when preparing a quality system for a subsequent audit in application of the sections 3 and 4 of Annex II of the Gas Appliance Directive.

The professional judgement of the Notified Body and the expertise of the manufacturer must be recognised; it should also be emphasised that it is the manufacturer who must decide which module to choose, and the responsibility of the Notified Body to evaluate whether or not the manufacturer's quality system meets the requirements of the Gas Appliances Directive.

To determine if there are sufficient procedures and instructions in the quality assurance system, which on a continuous basis can assure compliance with the Essential Requirements of the Gas Appliance Directive, it is necessary to work out quality plans.

*This guidance is for information only; it has no formal status*

Reference: 90/396/EEC "Gas appliances directive" O.J. L 196, 26.07.90, p. 15

Source of guidance document: GADAC

<b>Doc. Number</b>	<b>Rev. Number</b>	<b>Approved by GADAC</b>	<b>Approved by WG-GA</b>	<b>Withdrawn</b>
<b>C5</b>	<b>0</b>	<b>06/1996</b>	<b>06/2003</b>	

The quality plans must include testing of appliances or fittings.

In the material shown below, are given examples of tests, which often are necessary to assure conformity.

Nevertheless, manufacturers may expect to carry out additional tests on a sampling basis, e.g. EMC, Life Tests, Material Tests, etc. The matrix is therefore devised as a guide to the ongoing tests that are normally carried out on appliances/fittings to ensure continuous conformity with the Gas Appliances Directive.

### Quality plans for certification of gas appliances :

#### SUGGESTED TEST CRITERIA

TESTS	CENELEC STD HD 289/S1																						
	GAS SOUNDNESS	FLOW RATE (GAS)	BURNER IGNITION	BURNER AERATION (VISUAL APPEARANCE OF FLAME)	BURNER X LIGHTING	EARTH CONTINUITY	HIGH VOLTAGE	INSULATION RESISTANCE	FLAME SUPERVISION DEVICE	COMBUSTION	SURFACE TEMPERATURES	THERMOSTAT	PRESSURE LIMIT SWITCHES	FAN OPERATION	COMBUSTION CIRCUIT SOUNDNESS	FLUE GAS SPILLAGE	THERMAL DOWN DRAUGHT DIVERTER	CO2 DETECTION DEVICE VITIATION PILOT	WATER CIRCUIT SOUNDNESS	ELECTRIC CONTROLS (SAFETY)	TEMPERATURE LIMITS (SWITCHES)	EFFICIENCY	
APPLIANCES																							
COOKER	100%	100%	100%	100%	100%	100%	100%	100%	100%	§	§	§	I/A	100%	N/A	N/A	N/A	N/A	I/A	100%	N/A	§	§
C.H. BOILER	100%	100%	100%	100%	100%	100%	100%	100%	100%	§	§	§	100%	100%	§	§	§	§	100%	100%	§	§	§
INSTANTANEOUS WATER HEATER	100%	100%	100%	100%	100%	100%	100%	100%	100%	§	§	§	100%	100%	§	§	§	§	100%	100%	§	§	§
ROOM HEATER	100%	100%	100%	100%	100%	100%	100%	100%	100%	§	§	§	100%	100%	§	§	§	§	100%	100%	§	§	§
RADAIANT CONVECTOR HEATER	100%	100%	100%	100%	100%	100%	100%	100%	100%	§	§	§	100%	100%	§	§	§	§	100%	100%	§	§	§
WATER STORAGE HEATER	100%	100%	100%	100%	100%	100%	100%	100%	100%	§	§	§	100%	100%	§	§	§	§	100%	100%	§	§	§
GAS FIRE	100%	100%	100%	100%	100%	100%	100%	100%	100%	§	§	§	100%	100%	§	§	§	§	100%	100%	§	§	§
BACK BOILER	100%	100%	100%	100%	100%	100%	100%	100%	100%	§	§	§	100%	100%	§	§	§	§	100%	100%	§	§	§
OTHER APPLIANCES (if relevant)	100%	100%	100%	100%	100%	100%	100%	100%	100%	§	§	§	100%	100%	§	§	§	§	100%	100%	§	§	§

#### KEY

- 100% = These tests are actually carried out on every appliance produced bearing the CE Mark.
- S = These tests are actually carried out on a regular statistical basis, daily, weekly etc. at the manufacturers' discretion.
- N/A = This indicates that the particular tests are not applicable to the appliance.
- I/A = This indicates that the tests are usually carried out if the appliance is fitted with the component referenced.

./..

*This guidance is for information only; it has no formal status*

Reference: 90/396/EEC "Gas appliances directive" O.J. L 196, 26.07.90, p. 15

Source of guidance document: GADAC

Doc. Number	Rev. Number	Approved by GADAC	Approved by WG-GA	Withdrawn
C5	0	06/1996	06/2003	

**Quality plans for the certification of fittings :**

CONTROLS	GAS SOUNDNESS	FUNCTIONAL SAFETY (*)	ELECTRICAL SAFETY
Gas valves/ cocks	100%	100%	100%
Electric. temperature controllers	N/A	100%	100%
Mechanical (gas) temperature controllers	100%	100%	100%
Air flow and Pressure Level controllers	N/A	100%	100%
Gas pressure switches	100%	100%	100%
Igniters/sensors		100%	100%
Safety electronics	N/A	100%	100%
Other appliances (if relevant)	100%	100%	100%

(\*) These tests may relate to temperature limits and/or time

Key to matrix:

**100 %** = These tests are usually carried out on every appliance produced bearing the CE Mark

**S** = These tests are usually carried out on a regular statistical basis, daily, weekly, etc. at the manufacturer's discretion.

**N/A** = This indicates that the particular tests are not applicable to the appliance.

**I/A** = This indicates that the tests are usually carried out if the appliance is fitted with the component referenced

In Annex is given a list of terminology, which can be helpful in understanding the text of Annex II, Article 3 and 4 in the Gas Appliance Directive.

**Conclusion**

The Notified Body must ensure that sufficient tests form part of the manufacturer's quality assurance system, based on a quality plan as the example given in the above shown matrix.

Other similar approaches are equally applicable.

*This guidance is for information only; it has no formal status*

Reference: 90/396/EEC "Gas appliances directive" O.J. L 196, 26.07.90, p. 15

Source of guidance document: GADAC

Doc. Number	Rev. Number	Approved by GADAC	Approved by WG-GA	Withdrawn
C5	0	06/1996	06/2003	

## ANNEX

### Hints of terminology

---

The following terms, together with related definitions and considerations, can be helpful in understanding the Essential Requirements of Gas Appliances Directive, as defined in Annex II section 3 and 4.

**'Quality system'** is the organizational structure, responsibilities, procedures, processes, resources for implementing quality management in this context to ensure that CE marked products continue to meet the requirements of the Directive.

**'Quality plan'** in the context of the Directive, are those specific testing, inspection, examination, and product audit programmes unique to gas burning products which will ensure the continuing conformity of the product with the safety requirements.

**'Quality records'**, and charts pertaining to design data as appropriate for CE testing, inspection, survey, audit or review or related results, providing supporting evidence of continuing conformity with the safety requirements. Records must form part of the quality plan and be compatible with the requirements of the Directive, and any agreements between Notified Bodies.

**'Safety audit plans'** are the manufacturers means of defining the specific activities and responsibilities for persons auditing the company's quality system in an organized way, recording the results and taking appropriate action to ensure that the system continues to maintain the product with the safety requirements of the Directive.

**'Purchasing'** of products, components, and sub-contracted services used in the manufacturer of products carrying the CE marks must be procured from sub-contractors selected on their ability to meet the defined specification, and the capability performance.

In the context records of sub-contractors performance is an important factor and also the manufacturers system for corrective action, should the sub-contractor fail to meet the manufacturers specification.

**'Special processes'**: There will be processes within a company where the results cannot be verified by subsequent inspection and testing, and therefore appropriate tests must be specified.

**'Final inspection and testing'** must be included in the Quality Plans and include tests that will ensure that the product meets the safety requirements of the Directive. Such tests must be recorded, and available to Notified Bodies during assessment of the manufacturer's premises (Factory).

**'Inspection and measuring and test equipment'** used in the manufacturers verification of the product in relation to the safety requirements must be identified and calibrated, where appropriate, on a regular and formal basis and records retained.

**'Inspection test status'** is the method of identifying the test status of the product and can include, stamps, tags, labels, routing cards, test software, location, etc.

---

---

*This guidance is for information only; it has no formal status*

Reference: 90/396/EEC "Gas appliances directive" O.J. L 196, 26.07.90, p. 15

Source of guidance document: GADAC

Doc. Number	Rev. Number	Approved by GADAC	Approved by WG-GA	Withdrawn
C5	0	06/1996	06/2003	